

# Cell Specification

## IFR 18650 16E

**Powerful for you.**  
**Fast for everyone.**



E-Mobility



Industrial



Medical



Power- and  
Gardentools



Drive  
System



Energy Storage  
Systems

# IFR 18650 16E

## Cylindrical Lithium Ion Cell

### 1. Scope

The product specification describes the requirements of the Cylindrical Lithium-ion Cell to be supplied to the customer by TerraE. Should there be any additional information required by the customer, customer are advised to contact TerraE.

### 2. Description and Model

<b>2.1</b>	<b>Description</b>	Cylindrical Lithium Ion Cell
<b>2.2</b>	<b>Model</b>	IFR 18650 16E

### 3. General Specifications

<b>3.1</b>	<b>Nominal Capacity</b>	1600mAh (at 0.5C Discharge)
	<b>Minimum Capacity</b>	1550mAh (at 0.5C Discharge)

Nominal capacity is measured by the discharge at 0.5C to 2.5V end voltage after standard fully charged according to specification at 25°C.

<b>3.2</b>	<b>Maximum Charge Voltage</b>	3.65V
<b>3.3</b>	<b>Average Working Voltage</b>	3.20V
<b>3.4</b>	<b>Standard Charge Method (25°C ± 2°C)</b>	CC-CV to 4.2V          0.5C (800mA)
<b>3.5</b>	<b>Maximum Charge Current</b>	1C (at 25°C, not ideal for cycle life)

#### Recommended charge rates

0°C ≤ T ≤ 5°C	0.2C (320mA)
5°C < T ≤ 10°C	0.2C (320mA)
10°C < T ≤ 20°C	0.5C (800mA)
20°C < T ≤ 70°C	1C (1600mA)
70°C < T ≤ 75°C	0.2C (320mA)

<b>3.6</b>	<b>Standard Discharge</b>	Constant Current (CC)	1.0C (1600mA)
		End Voltage	2.5V

<b>3.7</b>	<b>Maximum Discharge Current</b>	3C (at 25°C, not ideal for cycle life)
------------	----------------------------------	--

#### Recommended discharge rates

-30°C ≤ T < -20°C	0.2C (320mA)
-20°C ≤ T < -10°C	0.5C (800mA)
-10°C ≤ T < -5°C	1.0C (1600mA)
-5°C ≤ T < 10°C	2.0C (3200mA)
10°C ≤ T < 45°C	3.0C (4800mA)
45°C ≤ T < 70°C	1.0C (1600mA)
70°C ≤ T < 75°C	0.2C (320mA)

# IFR 18650 16E

## Cylindrical Lithium Ion Cell

<b>3.8</b>	<b>Cycle Life</b>	80% SOH with 1C/1C at 25°C:	
		•	after 7000 cycles with 50% DOD
		•	after 4000 cycles with 80% DOD
		•	after 2000 cycles with 100% DOD
<b>3.9</b>	<b>Weight of Bare Cell</b>	≤39.5g	
<b>3.10</b>	<b>Operating Environmental Temperature</b>	Charge	0°C ~ 75°C
		Discharge	-30°C ~ 75°C
<b>3.11</b>	<b>Storage Temperature (For Shipping State)</b>	1 month	-20°C ~ 55°C
		3 months	-20°C ~ 45°C
		12 months	-20°C ~ 25°C

### 4. Outline Dimension (Unit: mm)

Dimension: Diameter max 18.60mm, Height max 65.50 mm. Refer to the attached drawing 1.

### 5. Appearance

There shall be no such defect as deep scratch, flaw, crack, rust, leakage, which may adversely affect commercial value of the cell.

### 6. Test condition and definitions

#### 6.1 Measuring Equipment

<b>6.1.1</b>	<b>Electronical Balance</b>	Parameter mileage 0.01g-160g, accuracy 1mg
<b>6.1.2</b>	<b>Manual Voltage-Impedance Tester</b>	Impedance: Parameter mileage 0-3.1kΩ, accuracy 0.1μΩ, The impedance meter should be operated at AC 1kHz
<b>6.1.3</b>	<b>Digital Caliper</b>	Parameter mileage 0-150mm, accuracy ± 0.02mm, resolution ratio 0.01mm

**6.2** Unless otherwise specified, all tests shall be performed at 25°C ± 2°C and humidity of 65%RH ± 20%RH. The cells used for the test mentioned should be new ones delivered a week before at most.

#### 6.3 Definition

##### **C Rate ("C"):**

The rate (milliamperes) at which a fully charged cell is discharged to its end voltage in one (1) hour.

### 7. Characteristics

#### 7.1 Charge Method

**7.1.1** Charging shall consist of charging at a 0.5C constant current rate until the cell voltage reaches 3.65V. The cell shall then be charged at constant voltage of < 3.65V while tapering the charge current. Charging shall be terminated when the charging current has tapered to 0.02C.

# IFR 18650 16E

## Cylindrical Lithium Ion Cell

### 7.2 Discharge Method

#### 7.2.1

Cells shall be discharged at a constant current of 0.2C to 2.5 volts.

#### 7.2.2

Cells shall be discharged at a constant current of 0.5C to 2.5 volts.

#### 7.2.3

Cells shall be discharged at a constant current of 1.0C to 2.5 volts.

#### 7.2.4

Cells shall be discharged at a constant current of 2.0C to 2.5 volts.

#### 7.2.5

Cells shall be discharged at a constant current of 3.0C to 2.5 volts.

### 7.3 Internal Impedance

The impedance shall be measured by 6.1.2

Initial Internal Impedance  $\leq 25\text{m}\Omega$

### 7.4 Discharge cap. retention

Cells shall be charged per standard charge method at  $25^{\circ}\text{C} \pm 2^{\circ}\text{C}$  and discharged per 7.2.1 (0.2C), 7.2.2 (0.5C), 7.2.3 (1C), 7.2.4 (2C), 7.2.5 (3C). The discharge capacity of each cell at respective discharge rate shall be compared with the discharge capacity at 0.5C and the percentage shall be calculated. Each cell shall meet or exceed the requirements of Table 1.

Table 1	
0.2C	100%
0.5C	100%
1.0C	$\geq 95\%$
2.0C	$\geq 90\%$
3.0C	$\geq 85\%$

### 7.5 Cycle Life

Stand for 5min, charge at 1C, and discharge at 1C to 2.5V, which is counted as one cycle. The interval between each cycle should not be less than 10 minutes. The test is completed when the discharge capacity is below 80% capacity at room temperature.

### 7.6 Storage Characteristics

#### 7.6.1

After charge as per standard charge method 7.1.1, store the testing cells at  $25^{\circ}\text{C} \pm 2^{\circ}\text{C}$  for 28 days. Then discharge as per 7.2.2. The recovery capacity of the battery was tested according to the charging and discharging standards. Capacity retention = storage capacity/initial capacity  $\geq 90\%$ . Capacity recovery = recovery capacity/initial capacity  $\geq 95\%$ .

# IFR 18650 16E

## Cylindrical Lithium Ion Cell

### 7.6.2

After charge as per standard charge method 7.1.1, store the testing cells at  $55^{\circ}\text{C} \pm 2^{\circ}\text{C}$  for 7 days. After the storage period expires, battery is placed for 5 hours at room temperature, and then discharged as per 7.2.2. The recovery capacity of the battery was tested according to the charging and discharging standards. Capacity retention = storage capacity/initial capacity  $\geq 90\%$ . Capacity recovery = recovery capacity/initial capacity  $\geq 95\%$ .

### 7.7 Temperature Characteristics

Cells shall be charged with 0.5C and discharged with 0.5C.

**Table 2**

-20 ° C	$\geq 40\%$
-10 ° C	$\geq 60\%$
0 ° C	$\geq 70\%$
10 ° C	$\geq 80\%$
25 ° C	$\geq 97\%$

## 8. Safety

### 8.1 External Short-Circuiting Test

After standard charging of normal batteries, direct short circuit positive and negative poles for 10 minutes, external line resistance should be less than  $5\text{m}\Omega$ . End the test when the battery temperature drops to about  $10^{\circ}\text{C}$  below the peak temperature and the appearance changes of batteries are observed for 1 hour.

**Criteria:** No Fire, No Explosion.

### 8.2 Overcharge Test

Normal batteries are charged at 1C constant current until the charging termination voltage is 1.5 times of after charging time reaches 1h, then stop charging and the appearance changes of the batteries are observed for 1h.

**Criteria:** No Fire, No Explosion.

# IFR 18650 16E

## Cylindrical Lithium Ion Cell

### 8.3 Overdischarge Test

Cell, charged per standard charge method, is discharged at constant current of 1C for 90min. The cell shall be observed for 1h afterwards.

**Criteria:** No Fire, No Explosion.

### 8.4 Heating Test (Thermal Abuse)

Cell, charged per standard charge method, is to be placed in the hot oven. The temperature was increased to  $130\pm 2^{\circ}\text{C}$  at a rate of  $(5\pm 2^{\circ}\text{C})/\text{min}$  and kept for 30 minutes. Then the appearance of the battery was observed for one hour.

**Criteria:** No Fire, No Explosion.

### 8.5 Drop Test

After standard charging of normal batteries, the initial state of the batteries was measured, and the test batteries were freely dropped from 1.5m height to flat cement ground, once in each direction.

**Criteria:** No Fire, No Explosion

## 9. Others

Any matter not included in this specification shall be conferred between the both parties.

# IFR 18650 16E

## Cylindrical Lithium Ion Cell

Attached 1: Cell Size Drawing

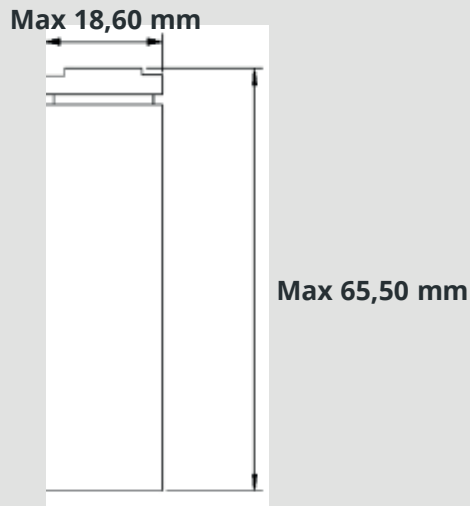

# IFR 18650 16E

## Handling Instructions

The following caution and warning should appear in manuals and/or instructions for users, especially at the point of use.

# Handling Instructions for Lithium Ion Rechargeable Cell

## 1. Charging Electric Car, Charger and Battery Pack Design Considerations

### 1.1 Charging

#### 1.1.1

The cell must undergo charging using a combination of constant current and constant voltage methods. The charging voltage for a single cell must not surpass 3.65V. Taking into account the charger's control deviation, the cell's charging voltage should be kept below 3.65V. It's important to note that a charging voltage higher than 3.65V will result in a reduced cycle-life for the cell.

#### 1.1.2

The charger needs to incorporate a pre-charging system, which serves to prevent excessively high power charging following a deep discharge. In instances where the cell voltage drops below 2.5V (0% State of Charge) due to long-term storage, it is necessary to pre-charge the cell using a current lower than (0.1C) until the voltage rises above 2.5V. Once this threshold is reached, the charger can switch to the standard charging mode. However, if the cell voltage fails to reach 2.5V within a 30-minute timeframe, the charger must automatically cease the charging process.

#### 1.1.3

Chargers should be equipped with a complete charge detection device. The charging detection device can be checked by timer, current detection or open circuit voltage detection to detect the charging state. When the charging detection device detects that the cell is fully charged, the charging circuit should be completely cut off to avoid trickling charge. The cell charge should be carried out at the temperature of 0°C ~ +75°C. When the cell temperature exceeds this range, it should be placed until the cell temperature reaches the above range.

#### 1.1.4

For cycle life, use the normal charging method with recommended currents.



# IFR 18650 16E

## Handling Instructions

### 1.2 Discharging

- 1.2.1 Single cell discharge current should be less than maximum discharge current.
- 1.2.2 The discharge cutoff voltage of the cell shall be higher than 2.5V;
- 1.2.3 The discharge temperature of the cell range from -30°C to +75°C. During the discharge process, if the surface temperature of the cell exceeds 75°C, the discharge must be terminated.
- 1.2.4 If the voltage of a single cell is lower than 2.5V, the cell is considered to be over discharged and cannot be used anymore.

### 1.3 Storage

Any storage, cell should be in low humidity (less than 45%RH), no corrosive gas atmosphere area. And there is no press and condensation on the cell. Best temperature range -20°C ~ 20°C. For long storage, the soc of the cell must between 20% ~ 50% SOC, and the voltage of the cell must be checked before used.

- When stored within 1 month:** -20°C ~ 55°C
- When stored within 3 months:** -20°C ~ 45°C
- When stored within 12 months:** -20°C ~ 25°C

### 1.4 Precautions on Battery Pack Design

#### 1.4.1 Battery pack Shape, Mechanism and Material

The battery pack should be designed so that it cannot be charged by an unauthorized charger. The battery pack design should ensure that it does not connect to unauthorized equipment. The positive and negative ends of the battery pack should be designed to avoid short circuit or reverse connection. In addition, the battery pack should have an overcurrent protection device to avoid the occurrence of external short circuit. There should be no overlap between the positive and negative connection wires of the battery pack. The battery pack should be designed to prevent static electricity and dust, liquids, etc. The battery pack should be designed to consider that the electrolyte will not reach the protective circuit board even if the cells leakage happen. The design of the battery pack should ensure that the cells are fixed in the battery pack and not arbitrarily movable. The battery pack shall be structurally designed to prevent the occurrence of dents, deformations or other mechanical stresses on the cells in the event of a predictable fall. The flammability of materials used in the battery pack, such as double-sided tape and rubber, should be verified.

# IFR 18650 16E

## Handling Instructions

### 1.4.2 Battery pack structure (battery pack limits the number of batteries used)

The number of parallel connections is unlimited, but the battery pack must pass the overcharge test (the charging current of the overcharge test is the product of the maximum charging current of the charger and the number of parallel connections). The number of serial connections is unlimited, and series fuses are required. The cell should be kept away from heating electronic components to avoid deterioration of cell performance. Insulation should be provided between the PCB/A and the battery pack (e.g. plastic barrier for air isolation or non-thermal conductive insulation).

### 1.4.3 Protection Circuit insure safety of battery

The following protection circuit should be installed in the battery pack:

#### Over charge protection

For safety reasons and in order not to shorten cycle life, the maximum overcharge protection voltage of the single cell in each module should be less than 3.65V.

#### Over discharge protection

If the single cell voltage reaches 2.5V, TerraE recommends that the discharge current should be cut off by over discharge protection circuit, and the consumption current of the protection circuit should be no more than 100 $\mu$ A.

#### Over current protection

If the discharge current of a single cell exceeds about maximum discharge current, the overcurrent protection should cut off the discharge current.

#### Protection circuit power consumption:

In order to avoid over discharge mode in long-term storage, the current consumption of the battery pack protection circuit should be set as small as possible. When it is not in use for a long time, it is necessary to check the residual state of the cell regularly and ensure that each single cell in the battery pack cannot reach the over-discharge state.

### 1.4.4 Cell connection

The cells cannot be connected using soldering process. In order to avoid any damage, resistance welding or laser welding is recommended for cell connection. Cells in battery pack should be temperature balanced. When the battery pack is discharging, the internal temperature difference of the battery pack should be less than or equal to 5°C.

# IFR 18650 16E

## Handling Instructions

### 1.5 Cell Usage

- 1.5.1 When the cell is used in tandem, the same grade, the same batch and the same charging state are necessary. This information can be obtained from the label of the inner and outer box. Before the cell is used, the voltage, internal resistance should be detected and assembled according to its purpose. TerraE suggests that the cell voltage within 20 mV and the internal resistance difference within 6mΩ should be guaranteed at least.
- 1.5.2 Check voltage, internal resistance, protection circuit function, thermistor, thermal fuse of battery pack before shipment.
- 1.5.3 Special attention should be paid to the transfer of the cell to the assembly plant. External damage caused by the transport process is forbidden. TerraE recommends using the same transport packaging, even if the packaging is opened during the process.
- 1.5.4 Do not use damaged or leaking cells which caused by transportation damage, drop, short circuit or other reasons.

### 1.6 Quality assurance immunity

- 1.6.1 Within one year of normal use, any quality problem caused by any manufacturing process, other than abuse, shall be solved by the manufacturer. Outside this period, the reason is not the manufacturing process but the cell quality problem caused by customer misuse. TerraE does not promise free replacement.
- 1.6.2 When conducting resistance welding and laser welding of cells, it is necessary to conduct DOE process experiment and confirm welding parameters. TerraE is not responsible for the safety problems related to internal damage of the cell caused by improper welding.
- 1.6.3 TerraE shall not be liable for any loss caused by violation of the specifications;
- 1.6.4 TerraE will not be responsible for any problems caused by design defects of battery packs and chargers.
- 1.6.5 TerraE does not accept abnormal cells due to improper assembly.
- 1.6.6 TerraE is not responsible for spot welders

## 2. Safety Instructions

Batteries containing organic solvents and other flammable substances, such as improper use may cause the core heat or fire, resulting in damage to the battery or personal injury. Please pay attention to the use of prohibited items, while the protection device should be added to avoid the use of equipment caused by abnormal batteries accident. Before using lithium-ion rechargeable batteries, please read the following safety guidelines carefully. In addition it is strongly recommended to add these instructions to the user manual.

### 2.1 Quality assurance immunity

- 2.1.1 Don't use or place batteries in high temperature (above 70°C) environment. Do not put it into fire, water or make it moisture. Do not repair or disassemble batteries, there is a risk of causing the batteries to ignite, overheat, leak or explode.

# IFR 18650 16E

## Handling Instructions

- 2.1.2** Don't place the batteries in a chaotic manner, away from metal and other conductive materials to avoid positive (+) negative (-) short circuit, do not reverse the positive (+) negative (-) pole
  - 2.1.3** Don't use non-specified charging equipment and violate charging requirements. Non-specified conditions charge will cause the battery to overcharge or abnormal chemical reactions, heat generation, smoke, rupture or fire.
  - 2.1.4** Don't connect the battery to the AC plug (outlet) or the car plug. The battery needs to have a specific charger. If the battery is connected directly to the plug, the battery may catch fire, smoke, explode, or cause heat.
  - 2.1.5** Don't overcharge, over-discharge, drive nail into the cell, strike it by hammer or tread and step on it.
  - 2.1.6** Don't hit or throw batteries. If the batteries appear to fall, please treat the waste, cannot continue to use.
  - 2.1.7** Don't dissect the battery. If the protection line is damaged, the battery will no longer be protected. Then, the battery may fire, smoke, explode or cause heat.
  - 2.1.8** Don't charge near high temperatures. If the battery is charged near the high temperature, the battery cannot be recharged due to the protection line. In this case, the protection circuit may be interrupted, the battery may fire, smoke, explode or cause heat.
  - 2.1.9** Don't use batteries that are clearly damaged or deformed. May cause fever, smoke, rupture or burning.
  - 2.1.10** Don't direct soldering of batteries, overheating will lead to insulation gaskets and other parts of the deformation, causing cell deformation, leakage, explosion or fire.
  - 2.1.11** Don't reverse polarity charge. In the case of charging, the battery is reverse charging will be abnormal chemical reaction. In addition, there is an unpredictable high current through the discharge. These may cause heat, smoke, rupture or burning.
- 2.2 Warning**
- 2.2.1** Batteries should be kept away from infants and young children. In case of swallowing the battery, please seek medical attention immediately.
  - 2.2.2** Don't place the battery in a microwave oven or other cooking utensils. Due the heating and electrical shock of the microwave oven, the battery may ignite, smoke, explode or cause heat.
  - 2.2.3** Don't mix with other batteries. The battery cannot be mixed with other different capacities, chemical systems, or manufacturers' batteries. Do not connect other batteries or mix other batteries. The battery may catch fire, smoke, explode or cause heat.
  - 2.2.4** Don't use an abnormal battery. If there are obvious abnormalities, such as odor, fever, deformity or discoloration, stop using the battery. Such batteries may be defective and, if used, may cause fire, smoke, heat or explosion.

# IFR 18650 16E

## Handling Instructions

- 2.25** If the charging process does not end, stop charging. If the battery cannot complete the charging process for a specified period of time, stop the charging step. The battery may catch fire, smoke, explode or cause heat.
  - 2.26** Don't use a leaky battery near a flame. If the battery or liquid out of the battery produces a pungent odor, the battery should remain away from the flame. The battery may be ignited or exploded.
  - 2.27** Don't touch the leaky battery. If the liquid leaking from the battery into the eyes, will cause serious damage. If you come from your leaked liquid into your eyes, rinse your eyes with water immediately. Please consult a doctor immediately. If the liquid is left in the eyes, it will cause serious damage.
  - 2.28** In order to avoid short circuit or damage, please tightly put the battery into a box or carton.
  - 2.29** Don't store the cell in a pocket or a bag together with metallic objects such as keys, necklaces, hairpins, coins, or screws.
- 2.3 Precautions**
- 2.3.1** Don't use or place batteries in high temperature environments, such as in direct sunlight. The battery may catch fire, smoke, explode or cause heat. At the same time, may cause battery performance and life degradation.
  - 2.3.2** Battery pack has a protective line. Do not use batteries in places where static electricity (over 100V) is generated, which may damage the protection circuit. If the protective line of the battery is damaged, the battery may catch fire, smoke, explode or cause heat. Do not use Lithium ion cell with the primary batteries or secondary batteries whose capacity or kinds or maker is different. If do that, the cell will be discharged or charged excessively in use. And it may cause the generating heat, smoke, rupture or flame because of the abnormal chemical reaction in cells.
  - 2.3.3** Do not charge the battery outside the specified temperature range. Failure to do so may result in heat, leakage, or serious damage. In addition, battery performance and life degradation may occur.
  - 2.3.4** Please read the manual before use. Please keep this manual for future reference.
  - 2.3.5** Please read the charging method of the charger manual.
  - 2.3.6** In the first use, if the battery has an abnormal smell, heat or rust, please contact the supplier
  - 2.3.7** Keep away from flammable materials during charging and discharging. May cause fire, smoke, explode or cause heat.
  - 2.3.8** If the electrolyte leaks from the battery, gets on the clothes or on the skin, rinse it immediately with water. Otherwise it may irritate the skin.
  - 2.3.9** If wires or metal objects come out of the battery, completely seal and insulate them. Otherwise, the battery may cause a short circuit, fire, smoke, explosion, or cause heat.
  - 2.3.10** After use, please carry out battery recycling according to local laws and regulations.

# IFR 18650 16E

## Handling Instructions

### 3. Exclusion Liability

- 3.1 TerraE is not liable for any loss caused by breach of notice in the specification
- 3.2 TerraE is not responsible for any problems caused by design defects in battery packs, electric cars and chargers
- 3.3 TerraE does not accept abnormal batteries caused by improper assembly
- 3.4 TerraE is not liable for any loss caused by incorrect or incongruent with the SPEC charge and discharge method and inappropriate environment
- 3.5 TerraE is not liable for any force majeure (ex. Lightning, storm, flood, fire, earthquake, etc)
- 3.6 In order to standardize the use of sample batteries, the rights, obligations and responsibilities of every customer and TerraE are clarified. Before using the battery, please read carefully and thoroughly understand the contents of the specification. In order to ensure the safety of the battery, please contact TerraE to discuss design of the application. Also, if there are special usage conditions (for example: a large current load, a quick charge method, or a special usage pattern), please consult TerraE before finalizing the product specification.

If you choose to use this battery, your use will be regarded as an endorsement of all the contents of this statement. The amendment, renewal and final interpretation of this statement are belong to TerraE.

## Any questions?

Contact us, we will be pleased to advise you.

### A full load of advantages

Customized cells tailored to your individual requirements with the best choice in Li-Ion technology for the coming development.



One-Stop Shop



Customized



High Quality



More Power



High Energy

#### Headquarter Germany

TerraE GmbH  
Zeche Gustav 1  
63791 Karlstein am Main

+49(0) 6188-9956-0  
info@terrae.com  
www.terrae.com

**Power** – the result of a better battery